

High Power Polarization Maintaining Isolator (HPMI Series)

The 1064 nm Polarization Maintaining Isolator is a micro optics device with low insertion loss, high isolation, high return loss, high extinction ratio and excellent environmental stability and reliability. It is ideal for amplifiers, fiber lasers and test instrument applications.

Specifications

Parameter	Unit	Value
Center Wavelength (λ_c)	nm	1064
Typ. Peak Isolation	dB	35
Min. Isolation, λ_c , 23 °C	dB	28
Typ. Insertion Loss, 23 °C	dB	1.7
Max. Insertion Loss, 23 °C and input power 300 mW	dB	2.0
Max. Insertion Loss, 23 °C and input power 1 W	dB	2.5
Max. Insertion Loss, 23 °C and input power 2 W	dB	3.0
Min. Extinction Ratio	dB	20
Min. Return Loss (Input/Output)	dB	50/50
Max. Average Optical Power	W	2
Max. Peak Power for ns Pulse	kW	10
Max. Tensile Load	N	5
Fiber Type		PM 980 Panda Fiber
Operating Temperature	°C	10 to +50
Storage Temperature	°C	0 to +60

*IL is 0.5 dB higher, RL is 5 dB lower, and ER is 2 dB lower for each connector added. Connector key is aligned to slow axis.

** The optical power handling capability will be max 1W when the isolator is terminated with connectors.

Package Dimensions

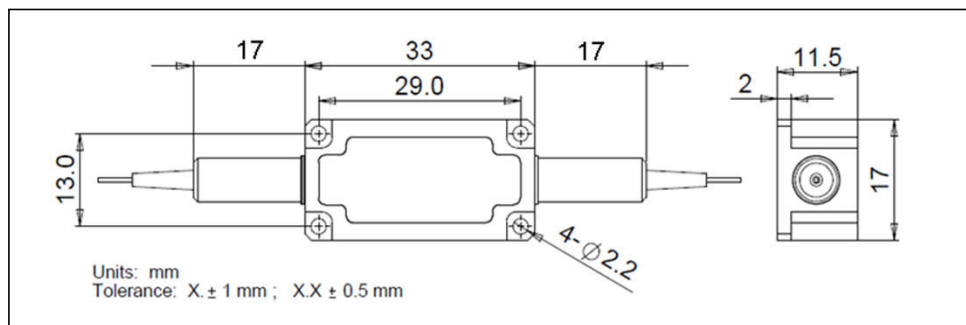

Ordering Information

HPMI-①①-②②-③④-⑤⑥-⑦⑧

①①: Wavelength

06 - 1064 nm

SS - Specify

②②: Handling Power

01 - 1 W

02 - 2 W

SS - Specify

③: Connector Type

1 - FC/UPC

2 - FC/APC

N - None

3 - SC/UPC

4 - SC/APC

S - Specify

④: Fiber Jacket

B - 250 μ m Panda fiber

L - 900 μ m loose tube

S - Specify

⑤: Fiber Length

Q - 0.75 m

S - Specify

⑥: Working Axis

F - Fast axis blocked

B - Both axes working

⑦: Fiber Type

1 - PM 980 Panda fiber

S - Specify

⑧: Power Type

P - Pulsed

C - Continuous Wave