

## Polarization Maintaining Filter Wavelength Division Multiplexer (PMFWDM Series)

The Polarization Maintaining Filter Wavelength Division Multiplexer provides wavelength division multiplexing while maintaining signal polarization. The components are based on environmentally stable thin-film filter technology and are characterized with high extinction ratio, low insertion loss, and high return loss. They are ideal for high speed WDM network systems.

### Specifications

Parameter	Unit	Value	
Pass Band	Wavelength Range	nm	980 ± 10
	Typ. Insertion Loss	dB	0.5
	Max. Insertion Loss)	dB	0.7
	Typ. Isolation	dB	30
	Min. Isolation	dB	25
Reflection Band	Wavelength Range	nm	1060 ± 40
	Typ. Insertion Loss	dB	0.4
	Max. Insertion Loss	dB	0.6
	Typ. Isolation	dB	15
	Min. Isolation	dB	12
Min. Return Loss	dB	50	
Min. Extinction Ratio	dB	20	
Fiber Type		PM 980 Panda fiber	
Max. Optical Power (Continuous Wave)	mW	300	
Max. Tensile Load	N	5	
Operating Temperature	°C	-5 to +70	
Storage Temperature	°C	-40 to +85	

\*IL is 0.5 dB higher, RL is 5 dB lower, and ER is 2 dB lower for each connector added. Connector key is aligned to slow axis.

### Package Dimensions

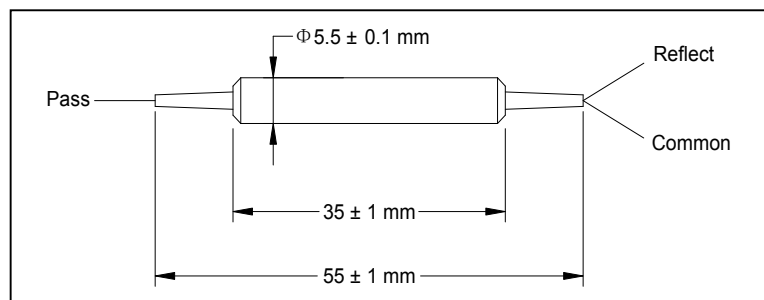

### Ordering Information

**PMFWDM-①①①①②③④**

①①①①: Wavelength  
9806 - 980 Pass/ 1060 Reflect

②: Connector Type

1 - FC/UPC  
2 - FC/APC  
3 - SC/UPC  
4 - SC/APC  
N - None  
S - Specify

③: Fiber Jacket

B - 250 μm Panda fiber  
L - 900 μm loose tube  
S - Specify

④: Fiber Length

Q - 0.75 m  
S - Specify