

Amplified Spontaneous Emission Filter (ASEF Series)

The Amplified Spontaneous Emission Filter series is designed to pass the specified wavelength range and block the unwanted amplified spontaneous emission noise in EDFAs and laser systems. It is a micro optics device based on environmentally stable thin film filter technology. The components are characterized with low insertion loss at pass channel, good isolation for blocking wavelengths and high power handling capability.

Specifications

Parameter	Unit	Value	
Pass Band	Wavelength Range	nm	1544 - 1565
	Max. Insertion Loss	dB	0.6
	Typ. Insertion Loss	dB	0.4
Reflection Band	Wavelength Range	nm	1510 - 1538
	Min. Isolation	dB	16
Min. Return Loss	dB	50	
Max. Polarization Dependent Loss	dB	0.05	
Thermal Stability	dB/°C	0.005	
Max. Optical Power (Continuous Wave)	mW	300	
Max. Tensile Load	N	5	
Fiber Type		SMF-28 fiber	
Operating Temperature	°C	-5 to +70	
Storage Temperature	°C	-40 to +85	

*IL is 0.3 dB higher, RL is 5 dB lower for each connector added.

Package Dimensions

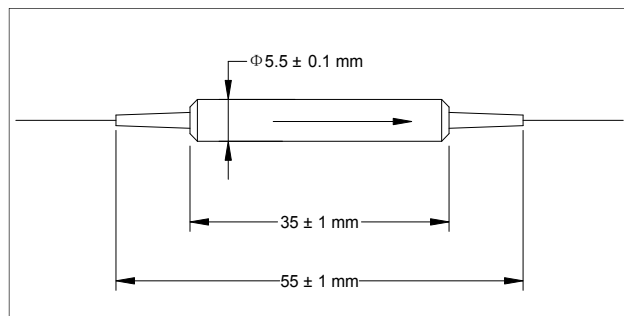

Ordering Information

ASEF-①①①①②③④

①①①①: Wavelength

1544 - 1544 nm

SSSS - Specify

②: Connector Type

1 - FC/UPC

2 - FC/APC

3 - SC/UPC

4 - SC/APC

N - None

S - Specify

③: Fiber Jacket

B - 250 μm bare fiber

L - 900 μm loose tube

S - Specify

④: Fiber Length

1 - 1.0 m

S - Specify